



SAPPHIRE
UPVC PROFILES



UPVC WINDOWS & DOORS

PROFILE CATALOGUE

**SAPPHIRE
COMMOTRADE PVT. LTD**

**2ND FLOOR, NEW GOLDEN PLAZA,
BURDWAN ROAD,
SILIGURI 734001**



INTRODUCTION

SAPPHIRE COMMOTRADE PVT.

UPVC, also known as Unplasticized Polyvinyl Chloride, is a low-maintenance building material that is commonly used as a substitute for painted wood, particularly for window frames and sills when installing double glazing in new structures or replacing existing single glass windows. What's more, UPVC is a less expensive alternative to pricey hardwood lumber and aluminium. It is a popular material owing to its durability and cost-effectiveness. The incredible strength, adaptability, and minimal maintenance are due to the use of vinyl polymer that is bonded to chlorine atoms, resulting in window frames that are not technically plastic and can work well with steel. This ensures that homeowners will not incur significant recurrent fees. If you want to save energy, UPVC is the way to choose because energy-rated UPVC windows are incredibly thermally efficient. Because of the materials used in their manufacture, they have relatively poor heat conductivity. This prevents heat from escaping as quickly as it might with other construction materials. The fundamental benefit of all high-quality UPVC items is that they never need to be painted, and the only care they really need is a wash down with a damp cloth every couple of years or so.

ABOUT US

Sapphire is one of Eastern India's largest manufacturers of uPVC profiles for windows and doors.

Our profiles meet the BS EN 12608 standard and have a unique formulation for the tropical Indian environment with particular additives that ensure the windows and doors last a long time.

Our cutting-edge infrastructure is in Siliguri, and we use worldwide standard extrusion gear to manufacture uPVC profiles. We also have an uPVC window and door fabrication unit with all of the advanced machineries and necessary equipment, which is managed and maintained by qualified professionals.

We uphold the highest corporate principles and ethics, and we strictly stick to our quality rules. Our devoted customer support team works around the clock to assist us in providing excellent service.

PROFILE CATALOGUE

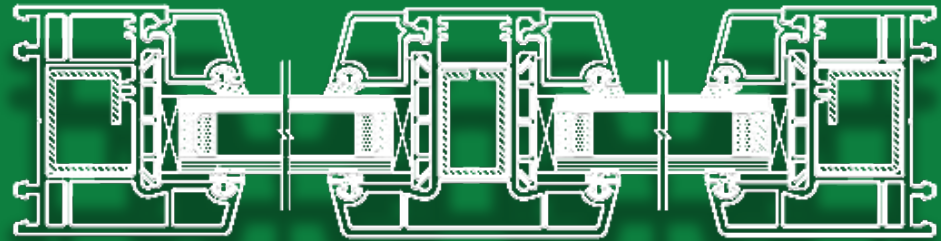
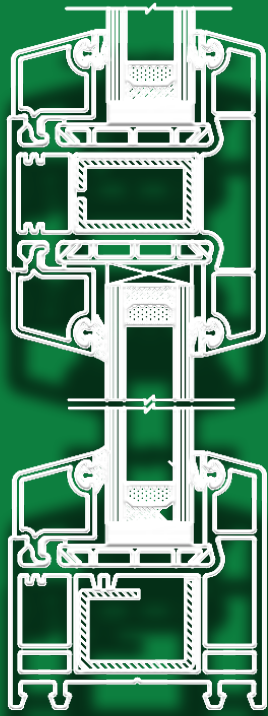

60A SERIES

MAIN PROFILES: Three-chamber structure, separate drainage chamber

OPENING METHOD: Inward or Outward opening, inward opening with tilt and fixed window

COLOR SELECTION: Several colors can be chosen, color co-extrusion suitable

GLASS DISTANCE: 5mm, 18mm, 28mm, 32mm, single, double or triple insulating glasses

COUPLING METHOD: 90°, 135°, 180° ordinary or enhanced, arbitrary angle also available

ECONOMIC: Higher window output rate with almost no performance loss to the final product

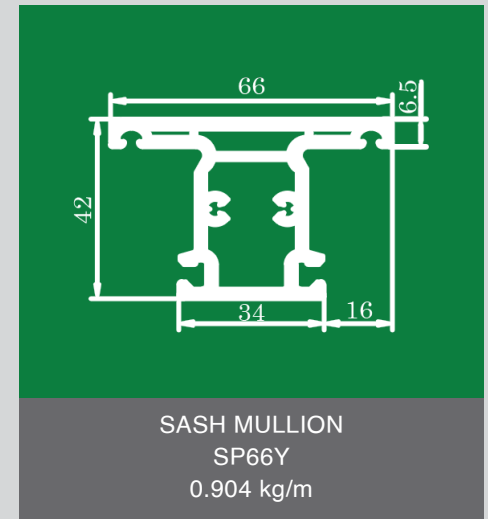
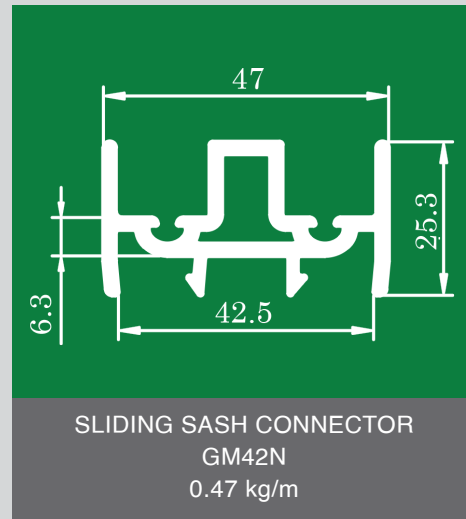
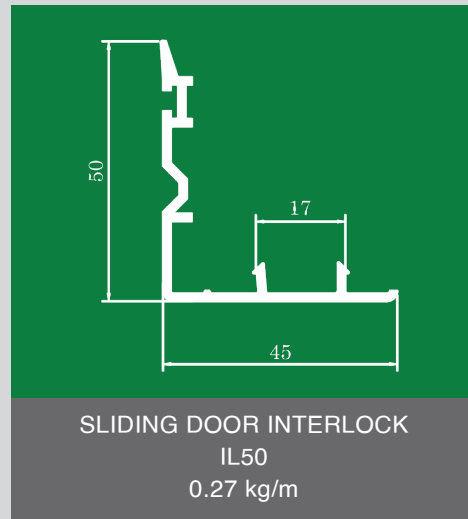
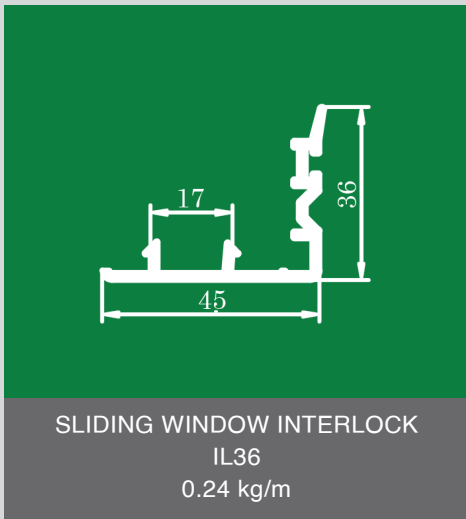
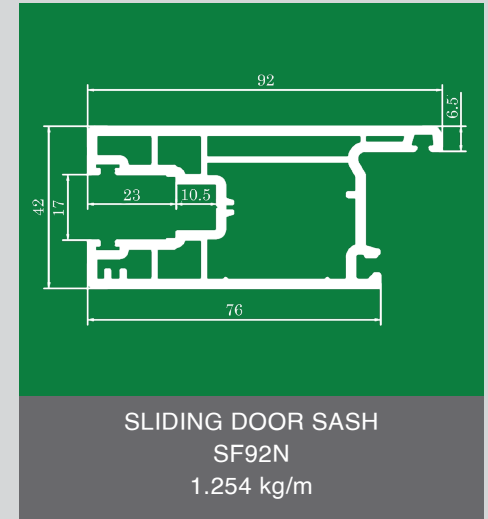
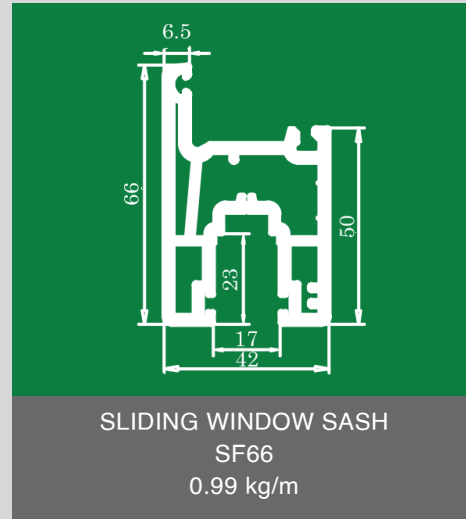
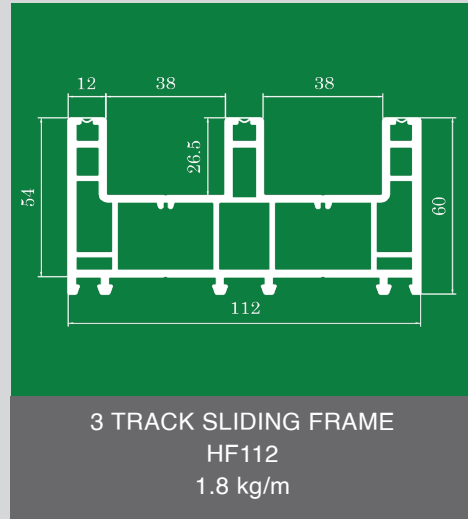
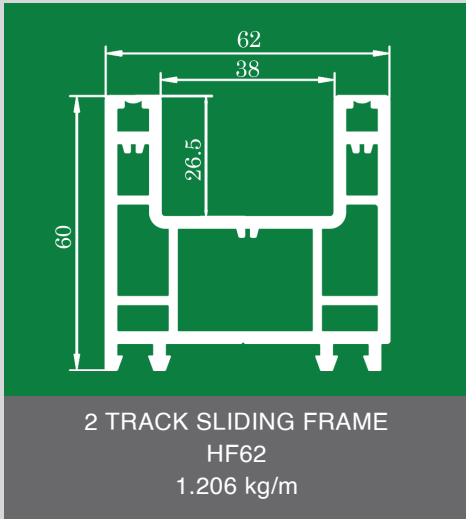

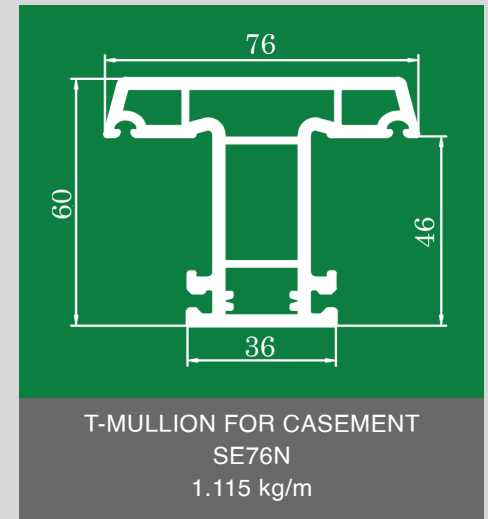
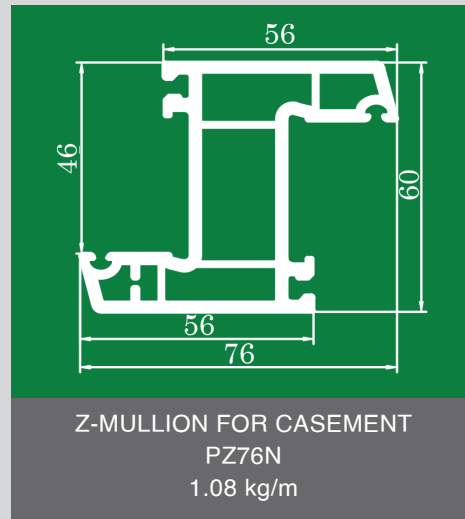
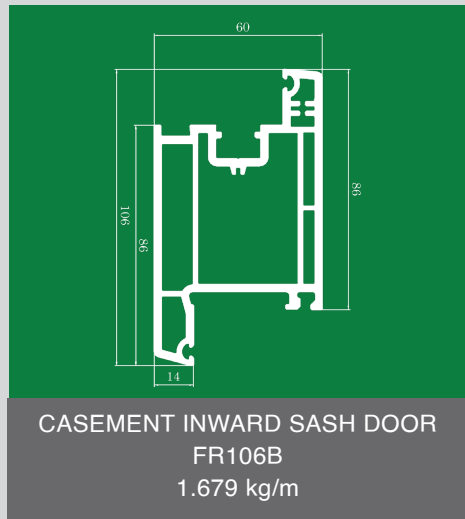
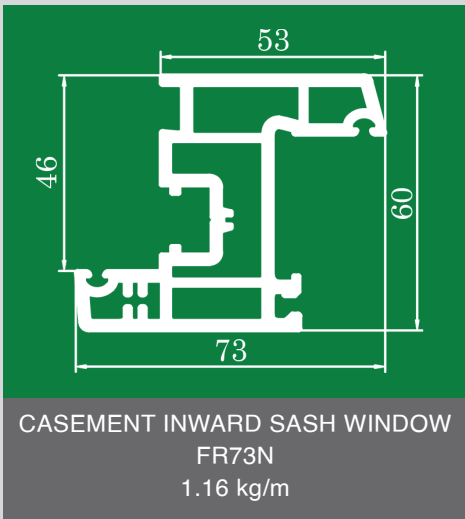
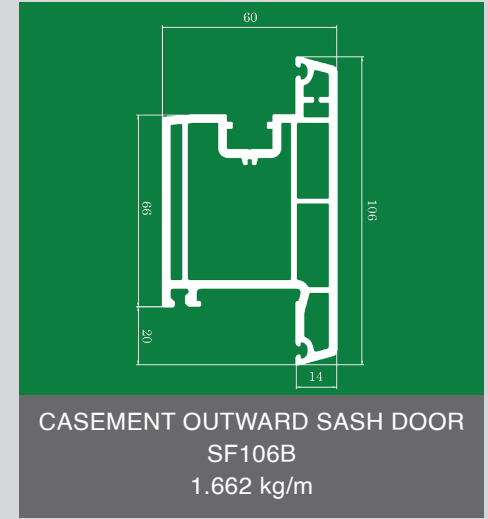
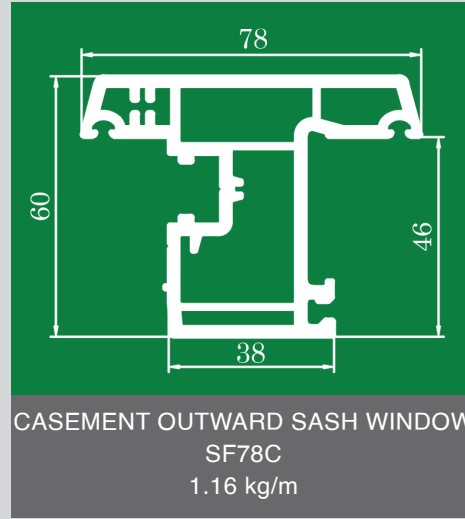
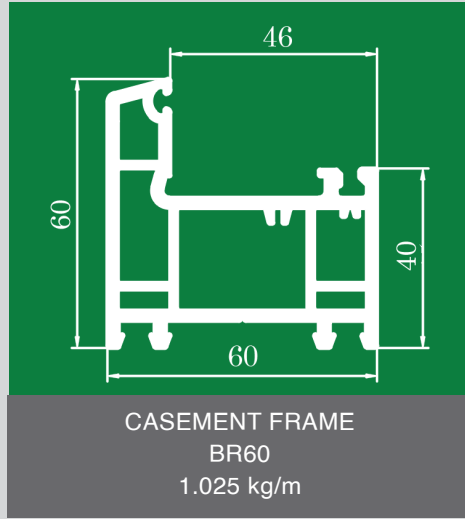
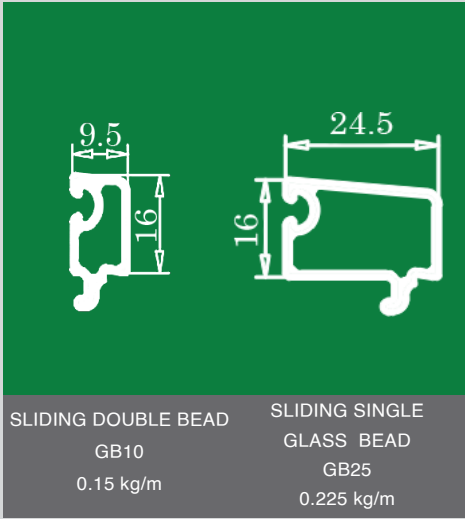

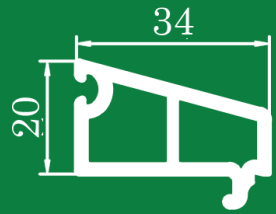

CASEMENT SINGLE GLASS BEAD
GB34
0.29 kg/m

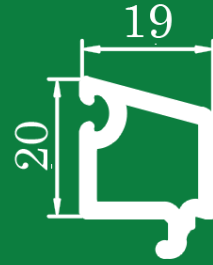

CASEMENT DOUBLE GLASS BEAD
GB19
0.215 kg/m

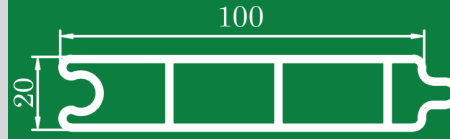

CASEMENT DOOR PANEL
PP100N
0.613 kg/m

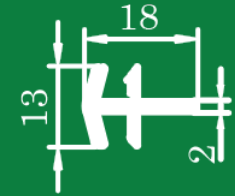

COUPLER
CP2
0.11 kg/m

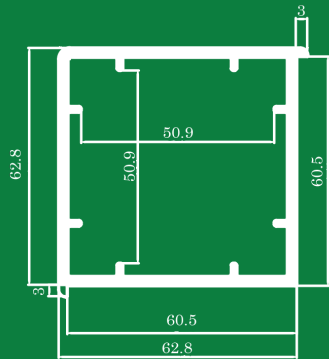

90 DEGREE CORNER
CP90C
0.965 kg/m

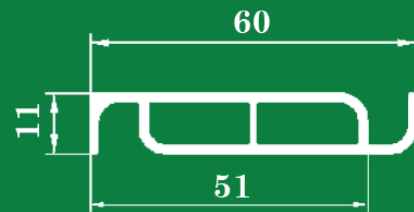

LOUVER BEAD
BY60
0.29 kg/m

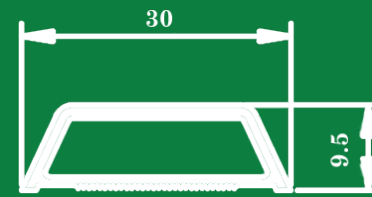

GEORGION BAR
ZS30
0.145 kg/m

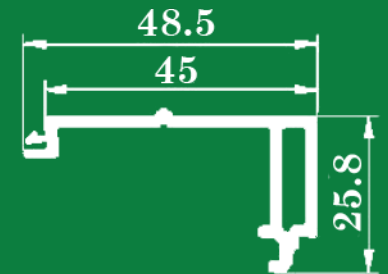

JALOUSIE WINDOW HOLDER
BK60
0.26 kg/m

FEATURES OF SAPPHIRE UPVC

We at Sapphire provide the best of the materials without compromising on cost and quality. Each Sapphire uPVC profile has an amazing design structure, colour, and size.

Even if we provide the finest of the best in terms of support, it is the knowledge of a fabricator that is most important in getting the most out of our uPVC profiles. As a result, it is strongly advised that you manufacture and install with care.

We are totally responsible for the quality of our uPVC profiles. Our Quality Control teams perform stringent quality checks at every stage of manufacturing, and our advanced automated and certified machinery ensures that our profiles meet every industry quality standard.



SAPPHIRE COMMOTRADE PVT. LTD

GSTIN : 19AANCS8308MIZK

OFFICE ADDRESS

**2nd Floor, New Golden Plaza,
Burdwan Road,
Siliguri - 734001**



FACTORY ADDRESS

**Demdema, Sanasekhata
Bhutkihat, Rajgung
Jalpaiguri - 735135**

 **+91-8972495765 +91-9434049127 +916296205620**

 **www.sapphireupvcwindows.com**

 **sapphire.upvc@gmail.com**